

TECHNICAL SPECIFICATION

Mesh Joanitów 12 x 12 (140 m2 mesh, 1200 x 1200 cm)

Artwork Requirements for production ready 11.8x11.8 mesh:

File Size: 1200 cm x 1200 cm on a scale 1:1 or 120 cm x 120 cm on a scale 1:10.

Safe Print Area (final format on a scale 1:1): critical graphics and text should be kept minimum 10 cm away from each edge of the printable area.

Mesh Layout:

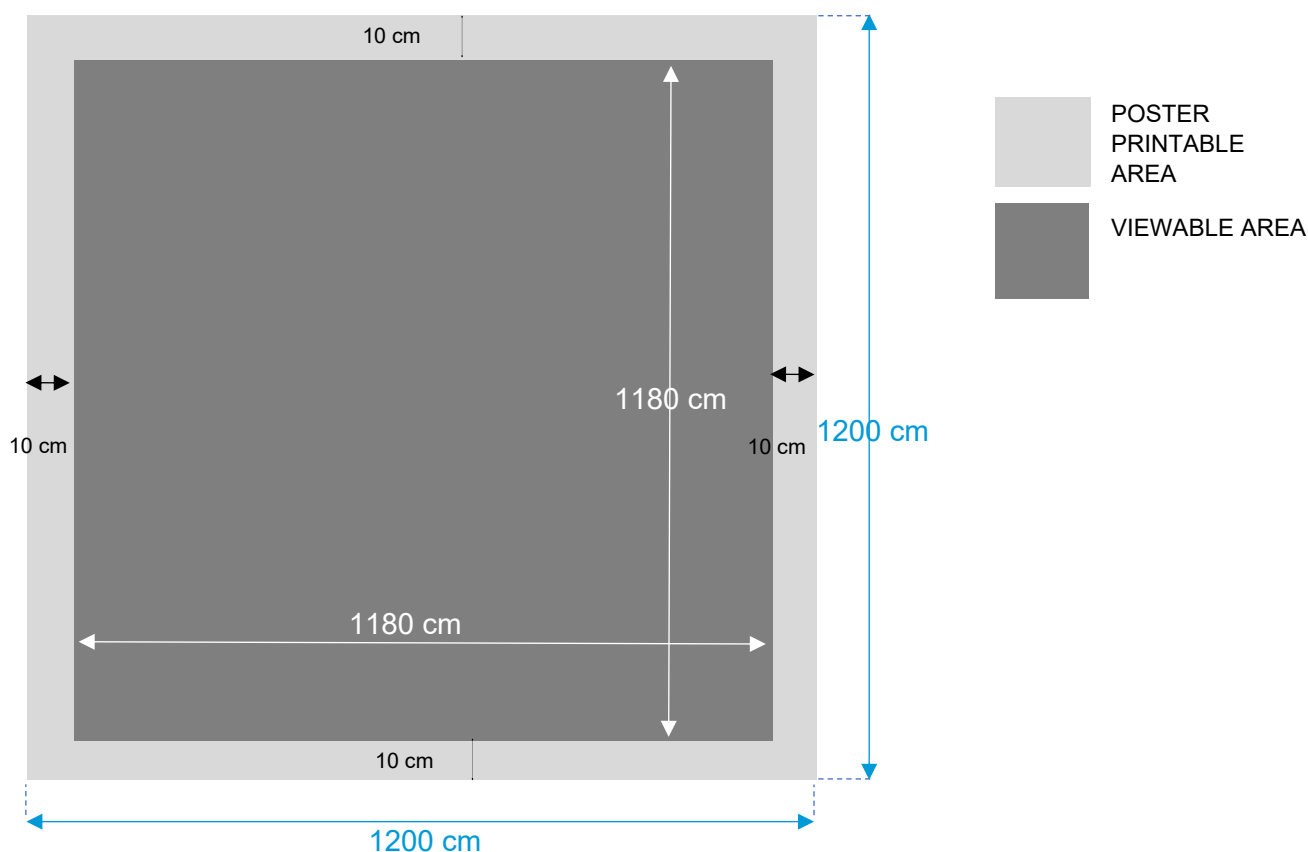

Resolution: 30-45 dpi on a scale 1:1 or 300-450 dpi on a scale 1:10.

Colouring: all files must be saved using CMYK colour mode. Other colour spaces (e.g. RGB) will be automatically converted to CMYK. Black backgrounds and objects: due to the specificity of printing technology, **we recommend using** for these objects only the black colour based on the CMYK C50 M50 Y50 K100 components.

File formats for printing:

- TIFF (flattened file without layers with LZW compression)
- PDF (press ready with bleed)
- EPS (fonts converted to outlines/vectors)

Attach a preview as a JPEG file to verify the file content for printing. Printable file should not include attached colour profiles. Overprint must not be used in files. The printing house is not responsible

for any errors in print if objects have overprint turned on. The file shall not include crop marks, registration marks, colour bars, etc. We do not accept files saved in CDR format.

The printing house is not responsible for any factual errors in the project (e.g. in texts). Be aware that the banding issue can occur, if the gradients are created improperly. Banding effect is a problem in printing a continuous tone images and refers to visible a visible bands, where one colour ends and the next starts, instead of an uniform, "smooth" transitions between colours.

Prepress proofing: cromalin or digital proof.

It should be noted that less colour fidelity is achieved with digital printing compared to offset printing using the cromalin or digital proof. Any digital printing performed by the printing house from the customer's digital media will be charged separately. Otherwise, we are not responsible for any colour reproduction not matching the customer's expectations.

It is possible to arrange for prepress proofing at a date agreed by the Parties. The date should be agreed with the responsible campaign sales representative at least 20 days before the start of the campaign. The prepress proofing should be attended by a person authorized to approve the prepress proof, preferably the Client and the representative of the creative agency, responsible for project preparation.

File transfer:

Materials should be sent to ftp. The login details will be provided by Clear Channel representative.

Please describe the files according to specification:

Campaign Date_Customer_Theme_Media Format

Deadline for delivery of files for printing:

10 business days prior to campaign start.

Date, address and method of submitting a cromalin or digital proof:

10 business days prior to campaign start sent to the following address:

Clear Channel Poland Spółka z o.o., 00-633 Warszawa, ul. Polna 11, "Sales Representative",
opening hours: Monday – Friday from 8:00 AM to 5:00 PM.

Requirements for assembly-ready materials:

- Mesh size (with pockets): 12 m x 12 m with threaded string,
- Mesh printable area: 12 m x 12 m,
- Mesh viewable area: 11.8 m x 11.8 m,
- Frontlight material Mesh 280 g.

Mesh Layout:

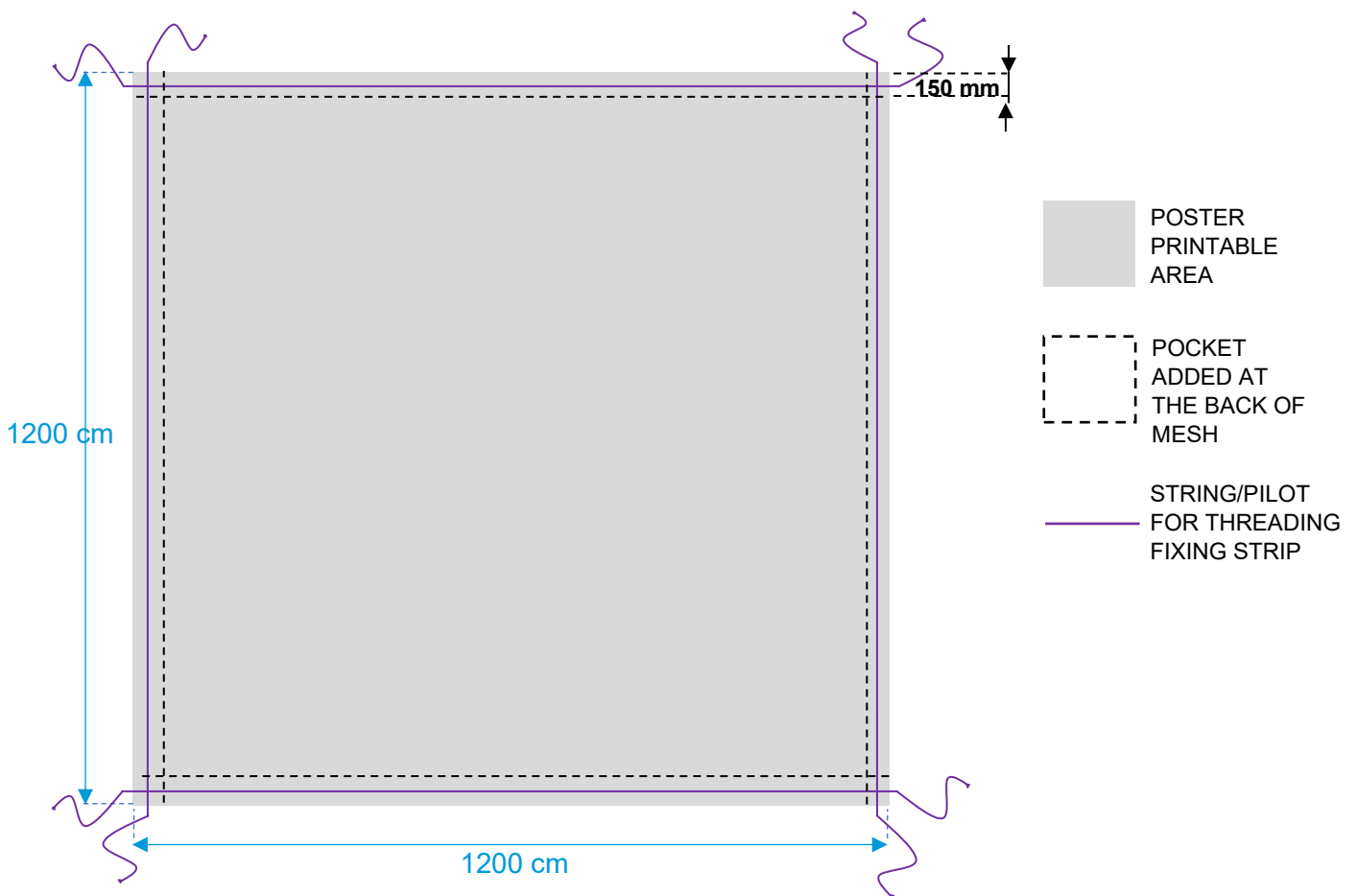

Delivery of finished materials printed out by the Client:

Mesh shipping requirements:

Each mesh should be individually wrapped with a banner and folded as follows: bottom (graphic) to top at a length of 12 m and then folded from the right side. Mesh should be labelled with the full campaign and theme name as well as the media format and number. Additionally, a list of media numbers and quantities for which the meshes were made shall be included in the Delivery Note.

Date and address for mesh delivery:

10 business days prior to the scheduled campaign start.

Adding correct labelling on all boxes with meshes delivered to our warehouse (at the expense of the client) is a prerequisite for timely pasting up the campaign materials. Labelling should contain the following information:

address of the receiving warehouse, the company name being the recipient of the posters - CCP, campaign/client name, campaign motive names, poster formats, quantities of posters in the box, label with a picture of the layout.

Example of a correctly completed Delivery Note:

RECIPIENT		ATS Digital Printing „Magazyn Clear Channel” ul. Nadarzyńska 53, 05-500 Piaseczno		
Company	Campaign Name	Theme Name	Exact mesh format and media no.	Quantity (pcs.)
Clear Channel Poland	Yogurts	Raspberry	12x12 no. ...	1 piece
Clear Channel Poland	Car	Sedan	12x12 no. ...	1 piece

Warehouse Address:

ATS Digital Printing „Magazyn Clear Channel”, ul. Nadarzyńska 53, 05-500 Piaseczno

e-mail: dystribucjacc@atsreklama.pl

mobile: 600 935 437

phone: (22) 7502245 ext. 101, 7503962, 7506474

or the address of another warehouse as previously agreed with respective sales representative.